

CHANNELED4 INSTALLATION GUIDE

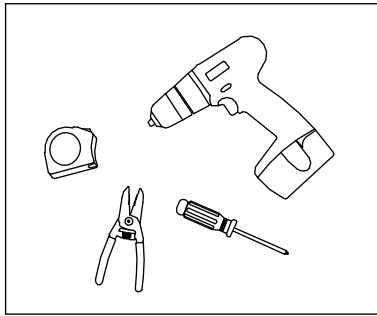

1. **Tools Required:** Measuring tape, wire strippers (optional: drill, screwdriver).

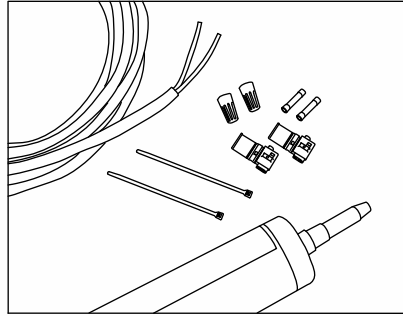

2. **Supplies Required:** PLTC cable, wire nuts, IDC connectors, or butt splices and cable ties. (Optional: screws and silicone).

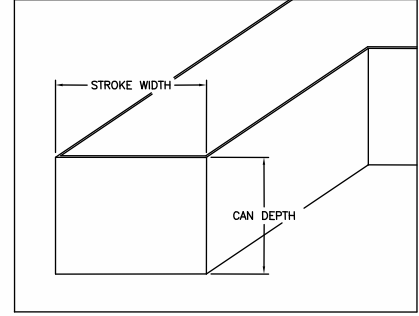

3. **Layout:** Noting can depth, stroke width and face material, use layout guidelines and power supply capacity charts below to determine spacing and amount of LEDs required.

Layout Density Guidelines:

Letter Height (inches)	LED Color	Stroke Width (inches)	Can Depth (inches)	Module Type	Linear Density (Modules / Ft)	Inches on Center (Standard)	Inches on Center (if dense translucent vinyl used)	Inches on Center (if perforated vinyl or dark colors used)	Max Coverage Per Row (inches)
< 25	Red	0-4	0-5	Mini	5	4	3	2	5
			> 5	Mini	4	4	3	2	5
		> 4	0-5	Mini	4	4	3	2	5
			> 5	Short	3	4	3	2	5
	Orange, Amber	All	All	Short	3	4	3	2	5
	Green, Blue, White Mini and Blue, Green Shorts	0-4	0-5	Mini	5	4	3	2	4
			> 5	Mini	4	4	3	2	4
		> 4	0-5	Mini	4	4	3	2	4
			> 5	Short	3	4	3	2	4
	White	> 5	Short	3	5	3	2	5	
≥ 25	Red	0-4	0-5	Mini	4	4	3	2	5
			> 5	Short	3	4	3	2	5
		> 4	0-5	Mini	4	4	3	2	5
			> 5	Long	2	5	4	2	5
	Orange, Amber	All	0-5	Short	3	4	3	2	5
		> 5	Long	2	5	4	2	5	
	Green, Blue, White Mini and Blue, Green Shorts	0-4	0-5	Mini	5	4	3	2	4
			> 5	Short	3	4	3	2	4
		> 4	0-5	Mini	4	4	3	2	4
			> 5	Short	3	4	3	2	4
	White	0-4	0-5	Mini	5	4	3	2	4
			> 5	Short	3	5	3	2	5
		> 4-7	0-5	Mini	4	4	3	2	4
			> 5	Short	3	5	3	2	5
		> 7	0-5	Mini	4	4	3	2	4
			> 5	Refer to ChanneLED 5 or Great White 3					

Note: These guidelines are intended to provide only an approximation of ChanneLED4 product required for your sign, assuming an optimal balance of performance and cost.

Items to consider:

1. It is recommended that you first test the LED density in a sample letter/cabinet to evaluate brightness, uniformity and color.

2. Should you have questions or require assistance in testing, please contact your SloanLED customer service representative.

Power Supply Capacity Chart:

Power Supply	Part # (Each)	Power Output	Maximum Number of Feet (Meters)					
			CL4 Long R/O/A	CL4 Short R/O/A	CL4 Mini Red	CL4 Short G/B	CL4 White Short	CL4 Mini G/B/W
Self Contained 20	701680	20 Watts	15 (4.5)	10 (3)	7.5 (2.3)	18 (5.5)	12 (3.7)	13 (4)
Mod 60/Mod 60-277	701507 Mod/Mod 60-277	60 Watts	45 (14)	30 (9)	22.5 (7)	54 (16.5)	37 (11.4)	40 (12)
Quad 240*	701494	240 Watts	180 (55)	120 (37)	90 (28)	216 (66)	149 (45.4)	160 (48)
Power Used per Foot (Meter) in Watts			1.2 (3.9)	1.8 (5.9)	2.4 (7.8)	1.0 (3.3)	1.44 (4.6)	1.4 (4.6)

*Quad 240 has four output legs; footages expressed are total (divide by four for footage per leg)

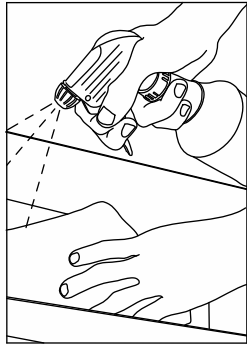

4. Clean Channel Letter: Clean inside the letter with rubbing alcohol and allow to dry.

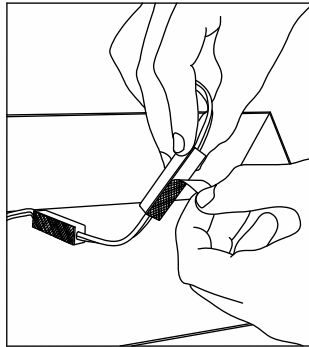

5. Peel and Stick: Using predetermined layout and LED placement from step 3, remove tape backing and stick modules into place. Ensure modules are firmly attached.

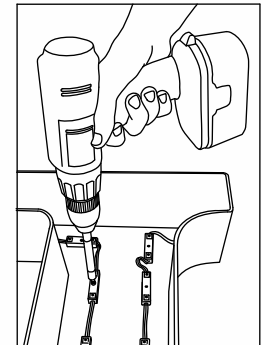
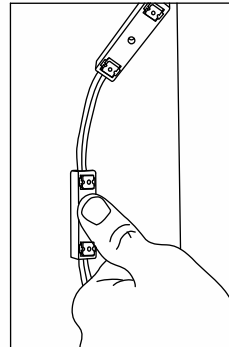

6. Fasteners: If desired, modules can be secured with #6 pan head sheet metal screws or 1/8" aluminum rivets. **Note:** If fasteners are used, insert from the top of the module ONLY.

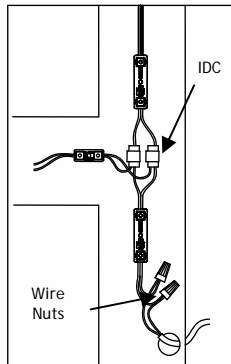

7. Connections: Modules may be connected in series or parallel with wire nuts, IDC connectors or butt splice connectors.

Warning!
Check Polarity:
All connections must be RED-TO-RED and BLACK-TO-BLACK. Reverse polarity connections may damage the LEDs and will void the product warranty.

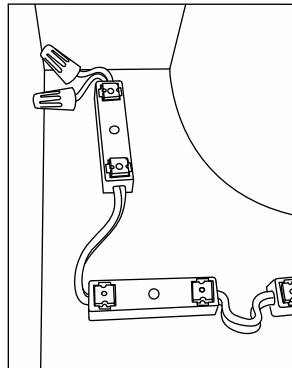

8. Cap all Unused Wires: The strand of modules should not be looped to create a closed circuit.

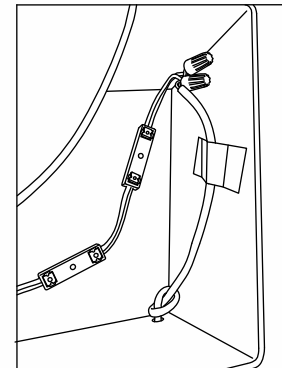

9. Connect Power Supply to First Module on String: See Power Supply Installation Guide for more information regarding power supply installation.

Extension of Power Supply Leads

If longer lead wire from power supply to LED modules is needed, an extension can be used. Extension should be kept as short as possible (under 15 feet for 18 AWG UL Listed PLTC or under 50 feet for 14 AWG UL Listed PLTC).

Troubleshooting:

Entire sign or leg does not light after complete installation.	Check connection from power supply lead to first module. Make sure polarity of connections made at the power supply lead and any jumper wire is correct. Power supply outputs should be connected red-to-red and black-to-black.
Still does not light.	Check output voltage of power supply using a voltmeter. The output voltage should be 12.0VDC \pm 0.5VDC. If there is no output voltage, have a licensed electrician check input voltage. Make sure power supply is connected correctly and getting primary power. If power supply is connected properly and getting primary power and there is still no output voltage, try a different power supply.
Still does not light.	If power supply is getting primary power and the modules don't light, there may be a short in the secondary wiring. Check all connections and cap all loose wires.
The beginning of a leg lights, but the entire leg does not light or lights intermittently.	The primary cause of a portion of a ChanneLED4 leg not lighting or lighting intermittently is a bad connection or reverse polarity connection between the modules that light and the modules that don't light. Check this connection.
Modules are dim.	Ensure maximum number of feet has not been exceeded (see Power Supply Capacity Chart). Check secondary voltage. If voltage is below 11.5VDC, power supply leg may be overloaded.
One module does not light, but all others in the leg light.	ChanneLED4 is designed so if one module fails, it will not cause the entire sign or leg to go out. If one module does not light, but all others in the leg do, replace this module with a new one.