

SignBOX Light

Installation Guide for part number 701946-CWSBL

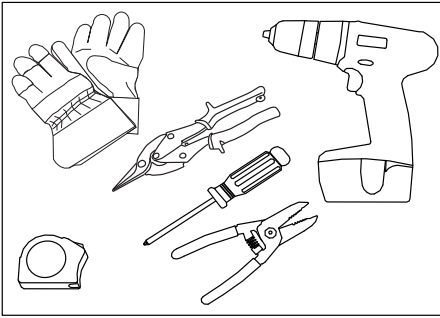

Tools required: Measuring tape, wire strippers, gloves, sheet metal sheers/snips, drill, and screwdriver.

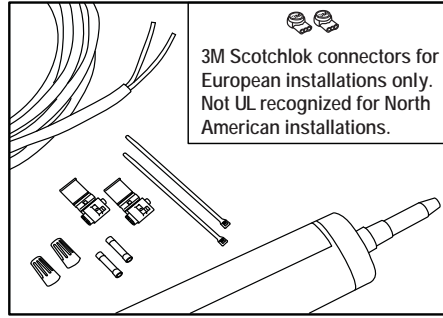

Supplies required: PLTC cable, wire nuts, IDC connectors or butt splices. (Optional: cable ties #8 (M4) pan-head screws, silicone and double stick tape.)
(3M Scotchlok connectors for European installations only.)

RETROFITS: For Retrofits refer to installation guide 400835-RET. This guide can be found on the SloanLED website under technical info or contact your SloanLED Customer Service Representative at 888.747.4LED.

NOTE: All materials removed must be disposed of in accordance with applicable local, state and federal laws.

Preparation for Install

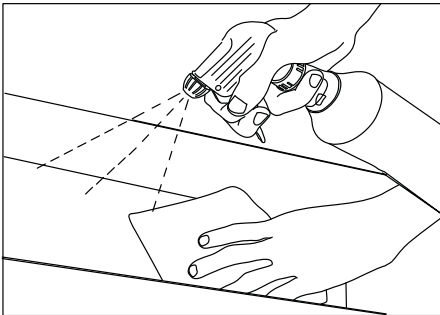

Clean cabinet/case: Using a non-oil based cleaner, clean inside surface of sign. If tape is to be used, be sure to clean any mounting surfaces with alcohol for proper tape adhesion.

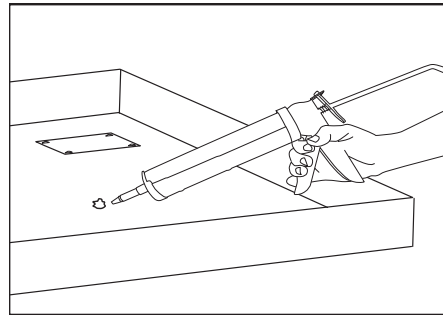

Patch box for replacements or retrofits: Any existing holes in sign that will be used for a new installation should be patched to avoid water damage to building and sign. Openings smaller than 1/2 in (13 mm) diameter may be sealed with non-hardening outdoor caulk. Openings larger than 1/2 in (13 mm) diameter require a metal patch secured by screws or rivets and caulked with non-hardening outdoor caulk.

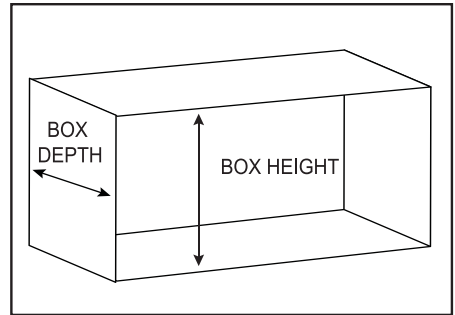

Measure cabinet/case height and depth: Measure from top to bottom of cabinet to determine required product lengths. Vertical installation is recommended to prevent SignBOX Modules from bowing due to gravity. To determine spacing and number of rows required, refer to the layout guidelines section.

Installation

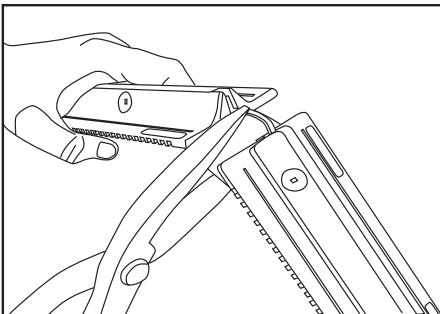

1. Cut strips to required length: Strips can be cut every 6 in (150 mm) between modules. Additional wire is stored at each end of module that can be pulled out for connecting to modules or power supplies.

CAUTION: Cut edges of sheet metal are extremely sharp. Use caution when handling.

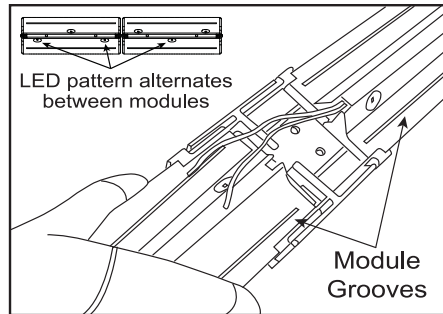

2. Joining cut strips: Use SignBOX Light couplers to join two shorter strips to required length. Adjoining modules should be flipped opposite of each other so LED pattern alternates between modules. Secure modules to coupler with #8 (M4) pan head self-tapping sheet metal screws anywhere along the module grooves.

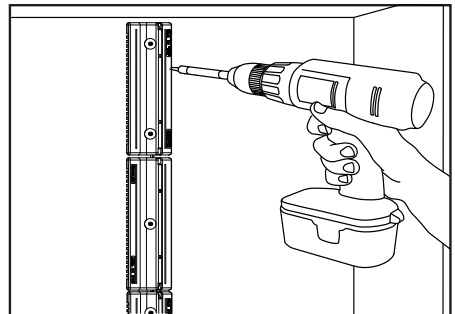

3. Mount SignBOX module: Mount modules to back of cabinet/case box using either #8 (M4) pan head self-tapping sheet metal screws anywhere along the module grooves or double stick tape (not included).



SignBOX Light

Installation Guide for part number 701946-CWSBL

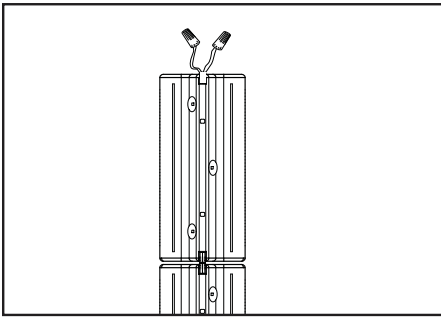

4. Cap all unused wires: The strand of modules should not be looped to create a closed circuit.

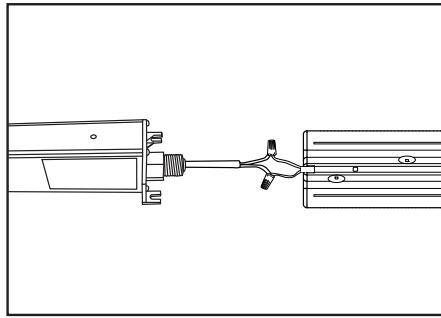

5. Connect to power supply: Using UL listed electrical connectors, daisy chain strips as required and connect to power supply. Strips may be daisy chained in series or parallel configurations.

WARNING check polarity:
All connections must be RED-TO-RED (+) and BLACK-TO-BLACK (-). Reverse polarity connections may damage the LEDs and will void product warranty.

Using mounting brackets

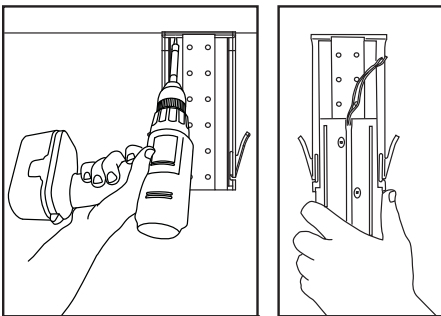

6. Mount brackets: Brackets can be mounted horizontally or vertically. Always mount brackets to structural supports. Snap modules into mounting brackets on both ends until strip is taut. To easily slide module into brackets press wings on either side of bracket.

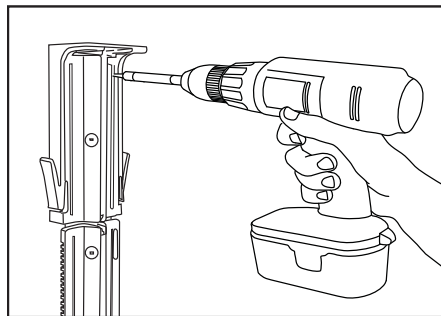

7. Secure modules: Secure modules to brackets with #8 (M4) pan head self-tapping sheet metal screws anywhere along the module grooves.

INSTALLATION TIP: Cutting only aluminum strip between modules allows strip to be stretched up to 7 in (175 mm) apart.

Layout guidelines for SignBOX Light

Box Depth	Center-to-center spacing	Special notes
<8 in (<200 mm)	Test for desired brightness	May need to be placed closer than 12 in (200 mm) center-to-center
8 in (200 mm)	12 in (305 mm)	
>8 in (>200 mm)	12 in (305 mm)	Mount in brackets placed 8 in (200 mm) from face

Note: These guidelines are intended to provide only an approximation of SignBOX Light product required for your sign, assuming an optimal balance of performance and cost. Items to consider:

1. It is recommended that you first test the LED density in a sample box to evaluate brightness, uniformity and color.
2. LED system operating temperatures -40° C to +70° C
3. Should you have questions or require assistance in testing, please contact your SloanLED Customer Service Representative.

Structural support guidelines for SignBOX Light

Vertical mounting: space supports at even intervals, but no further apart than 8 ft (2,4 m)

Horizontal mounting: space supports at even intervals, but no further apart than 6 ft (1,8 m)



Customer service and technical support
888.747.4LED (888.747.4533)
www.SloanLED.com • info@SloanLED.com

Europe: Customer service and technical support:
+31 (15) 3641569
www.SloanLED.eu • europe@SloanLED.com

SignBOX Light

Installation Guide for part number 701946-CWSBL

12 VDC Power Supply capacity table for SignBOX Light

Power Supply	Part # (Each)	Input		Output		Maximum modules per power supply
		Nominal Input Voltage	Input Current	Power Output	Output Current	
Self Contained 20	701680	120-240 V	0.3 A	20 W	1.5 A	10
Mod 60	701507-ModW	120-240 V	1.0 A	60 W	4.5 A	32
Mod 60-277	701507-Mod277	277-347 V	0.5 A	60 W	4.5 A	32
Quad 240*	701495	120-240 V	3.6 A	240 W	4.5 A / Leg	128
All footage based on 90% of rated capacity		Power used per foot (Meter) in Watts: 1.6 (5,2)				

*Quad 240 has four output legs; footages expressed are total (divide by four for footage per leg)

Extension of Power Supply Leads

If longer lead wire from power supply to LED modules is needed, an extension can be used. Extension should be kept as short as possible: Under 15 ft for 18 AWG UL Listed PLTC or under 50 ft for 14 AWG UL Listed PLTC. (4,6 m for 1,0 mm² or under 15,2 m for 2,5 mm²).

Troubleshooting:

Entire box/cabinet or strip does not light after complete installation.	Check connection from power supply lead to first module. Make sure polarity of connections made at the power supply lead and any jumper wire is correct. Power supply outputs should be connected RED-TO-RED and BLACK-TO-BLACK.
Still does not light.	Check output voltage of power supply using a voltmeter. The output voltage should be DC 12.0 V ± 0.5 V. If there is no output voltage, have a licensed electrician check input voltage. Make sure power supply is connected correctly and getting primary power. If power supply is connected properly and getting primary power and there is still no output voltage, try a different power supply.
Still does not light.	If power supply is getting primary power and modules don't light, there may be a short in the secondary wiring. Check all connections and cap all loose wires.
The beginning of a strip lights, but the entire strip does not light or lights intermittently.	The primary cause of a portion of a strip is not lighting or lighting intermittently is a bad connection or reverse polarity connection between modules that light and modules that don't light. Check this connection.
One module does not light, but all others in the strip light.	SignBOX Light is designed so if one module fails, it will not cause the entire box/cabinet or strip to go out. If one module does not light, but all others in the strip do, replace this module with a new one.

US patents and foreign patents pending



Customer service and technical support
888.747.4LED (888.747.4533)
www.SloanLED.com • info@SloanLED.com

Europe: Customer service and technical support:
+31 (15) 3641569
www.SloanLED.eu • europe@SloanLED.com