

## Installation Guide

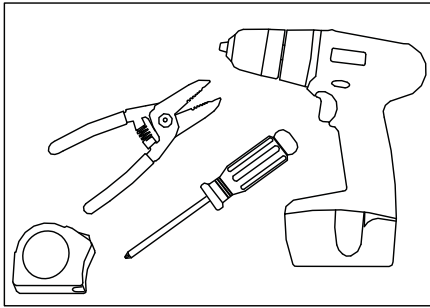

1. **Tools required:** Measuring tape, wire strippers (optional: drill, screwdriver).

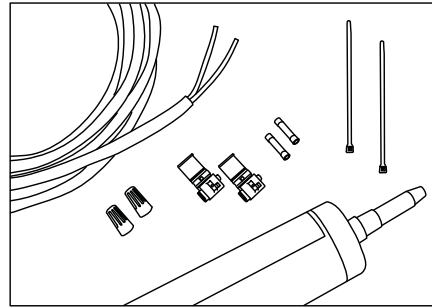

2. **Supplies required:** PLTC cable, wire nuts, IDC connectors or butt splices and cable ties (optional: screws and silicone).

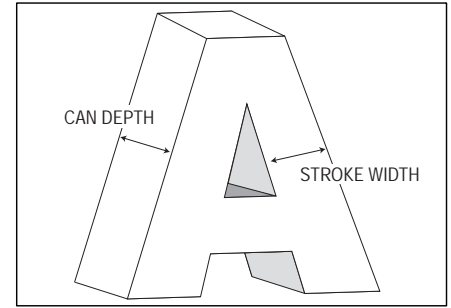

3. **Layout:** Noting can depth, stroke width and face material, use layout guidelines and power supply capacity charts on page 2 to determine spacing and amount of LEDs required.

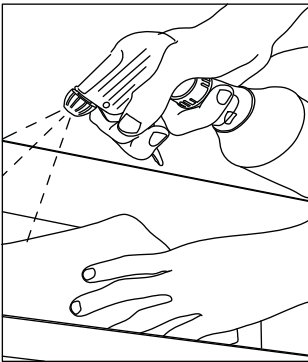

4. **Clean Channel Letter:**  
Clean inside the letter with rubbing alcohol and allow to dry.

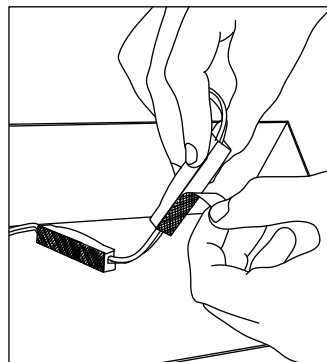

5. **Peel and Stick:** Using predetermined layout and LED placement from step 3, remove tape backing and stick modules into place. Ensure modules are firmly attached. (**CAUTION:** when handling the module, avoid pressing down directly on top of LED.)

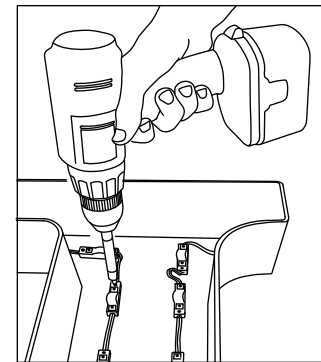
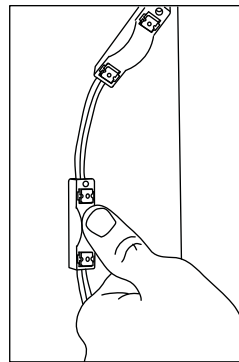

6. **Fasteners:** If desired, modules can be secured with #6 pan head sheet metal screws or 1/8" aluminum rivets.

### WARNING Check polarity:

All connections must be RED-TO-RED and BLACK-TO-BLACK. Reverse polarity connections may damage the LEDs and will void product warranty.

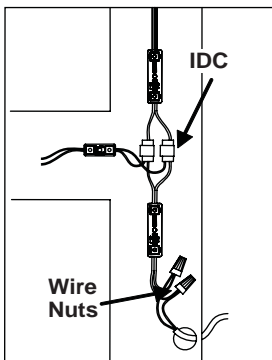

7. **Connections:** Modules may be connected in series or parallel with wire nuts, IDC connectors or butt splice connectors.

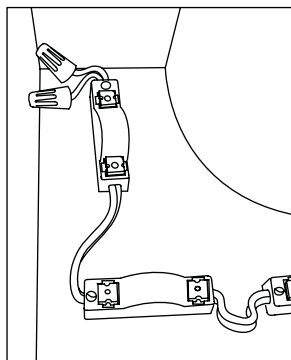

8. **Cap all Unused Wires:**  
The strand of modules should not be looped to create a closed circuit.

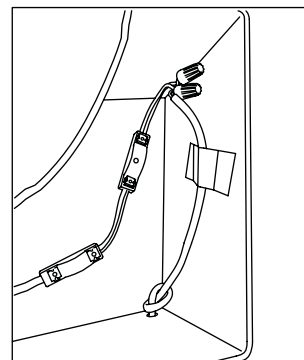

9. **Connect Power Supply to First Module on String:** See Power Supply Install Guide for more information regarding power supply installation.

# V Series

## Installation Guide

### Layout density guidelines for V Series

Module Color	Can Depth Inches (mm)	Modules per foot (m)	Inches (mm) on Center w/Standard Face	Inches (mm) on Center w/ Dark Vinyl	Inches on Center (mm) w/Perforated Vinyl	Inches (mm) Maximum Coverage per Row	<p><b>Note:</b> These guidelines are intended to provide only an approximation of Value Line product required for your sign, assuming an optimal balance of performance and cost. Items to consider:</p> <ol style="list-style-type: none"> <li>1. It is recommended that you first test the LED density in a sample letter/cabinet to evaluate brightness, uniformity and color.</li> <li>2. Should you have questions or require assistance in testing, please contact your SloanLED customer service representative.</li> </ol>
Red,	2.25 - 3 (57 - 76)	3 (10)	3 (76)	Test	Test	3.5 (89)	
Orange, Yellow,	>3 - 5 (>76 - 127)	3 (10)	5 (127)	4 (102)	3 (76)	6 (152)	
Whites,	>5 - 8 (>127 - 203)	3 (10)	6 (152)	5 (127)	4 (102)	7.5 (191)	
Blue, Green	2.25 - 3 (57 - 76)	3 (10)	3 (76)	Test	Test	3.5 (89)	
	>3 - 5 (>76 - 127)	3 (10)	4 (102)	3 (76)	2 (51)	5 (127)	
	>5 - 8 (>127 - 203)	3 (10)	5 (127)	4 (102)	3 (76)	6 (152)	

### 12 VDC Power Supply capacity chart for V Series

Power Supply	Part # (Each)	Input		Output		Maximum feet (Meter) / Modules  All Colors (Red, Orange, Yellow, Green, Blue, Whites)
		Nominal Input Voltage	Input Current	Power Output	Output Current	
Self Contained 20	701680	120/240 V	0.3 A	20 W	1.5 A	10 (3) / 30 modules
Mod 60	701507-Mod	120/240 V	1.0 A	60 W	4.5 A	30 (9) / 90 modules
Mod 60-277	701507-Mod277	277-347 V	0.5 A	60 W	4.5 A	30 (9) / 90 modules
Quad 240*	701494	120 V	3.6 A	240 W	4.5 A / Leg	120 (37) / 360 modules

Power used per Foot (Meter) in Watts: 1.8 (5.9)

\*Quad 240 has four output legs; footages expressed are total (divide by four for footage per leg)

### Extension of Power Supply Leads

If longer lead wire from power supply to LED modules is needed, an extension can be used. Extension should be kept as short as possible (under 15 feet for 18 AWG UL Listed PLTC or under 50 feet for 14 AWG UL Listed PLTC).

### Troubleshooting:

<b>Entire sign or leg does not light after complete installation.</b>	Check connection from power supply lead to first module. Make sure polarity of connections made at the power supply lead and any jumper wire is correct. Power supply outputs should be connected red-to-red and black-to-black.
<b>Still does not light.</b>	Check output voltage of power supply using a voltmeter. The output voltage should be 12.0VDC ± 0.5VDC. If there is no output voltage, have a licensed electrician check input voltage. Make sure power supply is connected correctly and getting primary power. If power supply is connected properly and getting primary power and there is still no output voltage, try a different power supply.
<b>Still does not light.</b>	If power supply is getting primary power and the modules don't light, there may be a short in the secondary wiring. Check all connections and cap all loose wires.
<b>The beginning of a leg lights, but the entire leg does not light or lights intermittently.</b>	The primary cause of a portion of a V Series leg not lighting or lighting intermittently is a bad connection or reverse polarity connection between the modules that light and the modules that don't light. Check this connection.
<b>One module does not light, but all others in the leg light.</b>	V Series is designed so if one module fails, it will not cause the entire sign or leg to go out. If one module does not light, but all others in the leg do, replace this module with a new one.



5725 Olivas Park Drive • Ventura, CA 93003 USA  
 805.676.3200 Fax: 805.676.3206  
 www.SloanLED.com • info@SloanLED.com

For customer service and technical support, contact  
 888.747.4LED (888.747.4533)