

1. **Tools required:** Measuring tape, wire strippers (optional: drill, screwdriver).

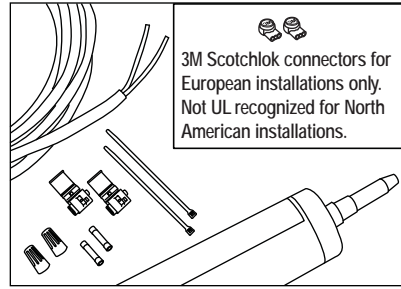

2. **Supplies Required:** PLTC cable, wire nuts, IDC connectors or butt splices and cable ties Optional: screws and silicone. **(3M Scotchlok connectors for European installations only.)**

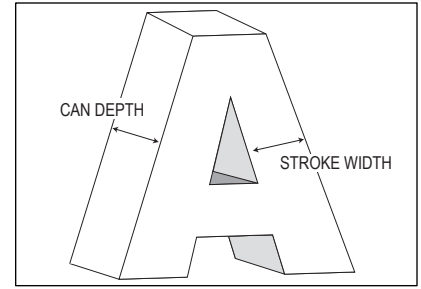

3. **Layout:** Noting can depth, stroke width and face material, use layout guidelines and power supply capacity charts on page 2 to determine spacing and amount of LEDs required.

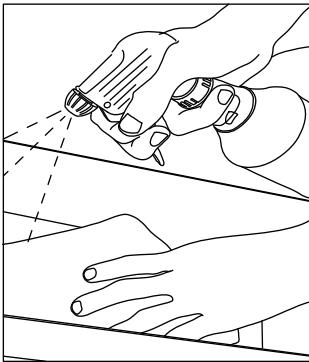

4. **Clean Channel Letter:** Clean inside the letter with rubbing alcohol and allow to dry.

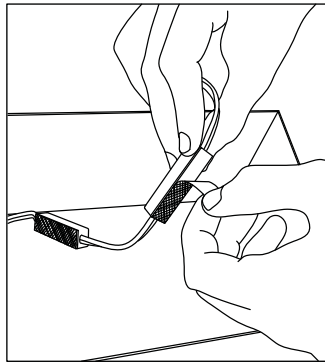

5. **Peel and Stick:** Using predetermined layout and LED placement from step 3, remove tape backing and stick modules into place. Ensure modules are firmly attached. **(CAUTION:** when handling the module, avoid pressing down directly on top of LED.)

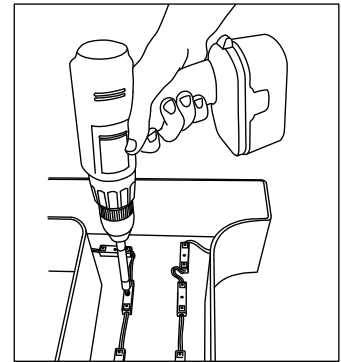
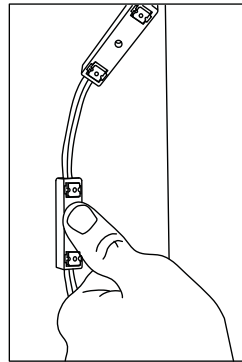

6. **Fasteners:** If desired, modules can be secured with #6 pan head sheet metal screws or 1/8 in (3 mm) aluminum rivets.

WARNING Check polarity:

All connections must be RED-TO-RED (+) and BLACK-TO-BLACK (-). Reverse polarity connections may damage the LEDs and will void product warranty.

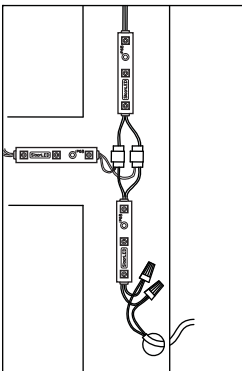

7. **Connections:** Modules may be connected in series or parallel.

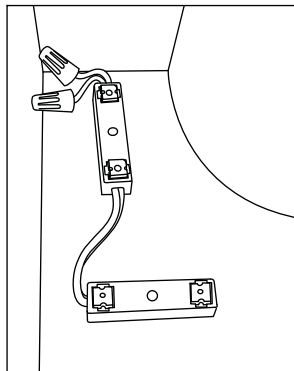

8. **Cap all Unused Wires:** The strand of modules should not be looped to create a closed circuit.

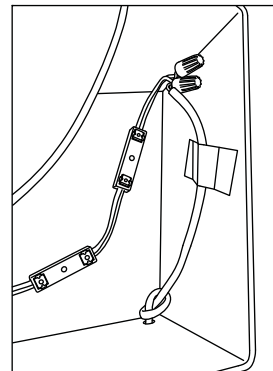

9. **Connect Power Supply to First Module on String:** See Power Supply Install Guide for more information regarding power supply installation.

Layout density guidelines for Value-Line

Module Color	Module Type	Can Depth Inches (mm)	Modules per foot (m)	Inches / millimeters on center						Maximum coverage per row			
				Standard Face		Dark Vinyl		Perforated Vinyl		Single Row		Multiple Rows	
				N.A.	EU	N.A.	EU	N.A.	EU	N.A.	EU	N.A.	EU
White	Mini	≥ 5 (125)	4 (13)	4 in	100 mm	3 in	100 mm	2 in	75 mm	5 in	125 mm	4 in	100 mm
	Short	≥ 5 (125)	3 (10)	4 in	125 mm	3 in	100 mm	2 in	75 mm	5 in	125 mm	4 in	100 mm
	Long	≥ 5 (125)	2 (6,5)	5 in	125 mm	4 in	100 mm	3 in	75 mm	6 in	125 mm	5 in	125 mm
Red	Short	≥ 5 (125)	3 (10)	4 in	125 mm	3 in	100 mm	2 in	75 mm	5 in	125 mm	4 in	125 mm
	Long	≥ 5 (125)	2 (6,5)	5 in	125 mm	4 in	100 mm	3 in	75 mm	6 in	125 mm	5 in	125 mm

Note: These guidelines are intended to provide only an approximation of Value-Line product required for your sign, assuming an optimal balance of performance and cost. Items to consider:

1. North American (N.A.) guides are based on commonly used face materials within North America, European (EU) guides are based on face materials commonly used within Europe.
2. It is recommended that you first test the LED density in a sample letter/cabinet to evaluate brightness, uniformity and color.
3. LED system operating temperatures -40° C to +70° C
4. Should you have questions or require assistance in testing, please contact your SloanLED customer service representative.

12 VDC Power Supply capacity chart for Value-Line

Power Supply	Part # (Each)	Input		Output		Maximum feet / Modules				
		Nominal Input Voltage	Input Current	Power Output	Output Current	Red Long	Red Short	White Long	White Short	White Mini
Self Contained 20	701680	120-240 V	0.3 A	20 W	1.5 A	15 / 30	10 / 30	25 / 50	17 / 50	17 / 67
Mod 60	701507-ModW	120-240 V	1.0 A	60 W	4.5 A	45 / 90	30 / 90	75 / 150	50 / 150	50 / 200
Mod 60-277	701507-Mod277	277-347 V	0.5 A	60 W	4.5 A	45 / 90	30 / 90	75 / 150	50 / 150	50 / 200
Quad 240*	701495	120-240 V	3.6 A	240 W	4.5 A / Leg	180 / 360	120 / 360	300 / 600	200 / 600	200 / 800
Power used per foot (Meter) in watts						1.2 (3,9)	1.8 (5,9)	.72 (2,4)	1.08 (3,5)	1.08 (3,5)

*Quad 240 has four output legs; footages expressed are total (divide by four for footage per leg)

Extension of Power Supply Leads

If longer lead wire from power supply to LED modules is needed, an extension can be used. Extension should be kept as short as possible: under 15 ft for 18 AWG UL Listed PLTC or under 50 ft for 14 AWG UL Listed PLTC. (4,6 m for 1mm² or under 15,2 m for 2.5mm²).

Troubleshooting:

Entire sign or leg does not light after complete installation.	Check connection from power supply lead to first module. Make sure polarity of connections made at the power supply lead and any jumper wire is correct. Power supply outputs should be connected red-to-red and black-to-black.
Still does not light.	Check output voltage of power supply using a voltmeter. The output voltage should be DC 12.0 V ± 0.5 V. If there is no output voltage, have a licensed electrician check input voltage. Make sure power supply is connected correctly and getting primary power. If power supply is connected properly and getting primary power and there is still no output voltage, try a different power supply.
Still does not light.	If power supply is getting primary power and the modules don't light, there may be a short in the secondary wiring. Check all connections and cap all loose wires.
The beginning of a leg lights, but the entire leg does not light or lights intermittently.	The primary cause of a portion of a Value-Line leg not lighting or lighting intermittently is a bad connection or reverse polarity connection between the modules that light and the modules that don't light. Check this connection.
One module does not light, but all others in the leg light.	Value-Line modules are designed that if one module fails, it will not cause the entire sign or leg to go out. If one module does not light, but all others in the leg do, replace this module with a new one.



Customer service and technical support
888.747.4LED (888.747.4533)
www.SloanLED.com • info@SloanLED.com

Europe: Customer service and technical support:
+31 (15) 3641569
www.SloanLED.com • Europe@sloanled.com